

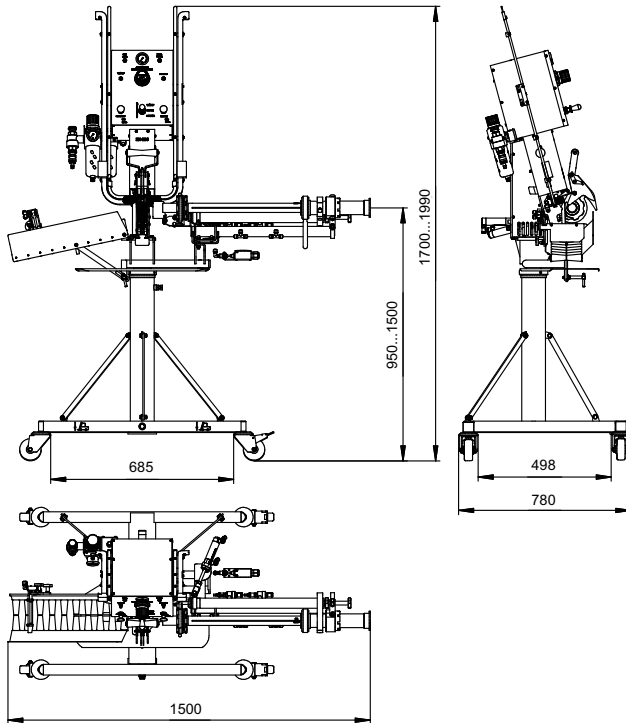

KOMPO KN-22S

PNEUMATIC DOUBLE CLIPPER





Double pneumatic clipper KN-22S is a reliable and use-friendly machine. It is designed for clipping various fillers in polyamide, cellulose, fibrous and collagen casings. The floor version of the KN-22S clipper makes it easy to move it in the workshop. Pneumatic clipper KN-22S provides high quality clipping and is suitable for a wide range of products.

Technical specifications:

Model	KN-22S
Clipping cycle, second	1,5 - 3
Casing caliber, mm	40-80
Clip type	B, BP
Clamping mechanism	manual
Clipping mechanism	pneumatic
Loop feed	manual
Version	floor standing
Distance from floor to stuffing horn, mm	950-1150
Air pressure, mPa	0,6-0,7
Air consumption per working cycle, liters	1,2
Dimensions, mm:	
Length*Width*Height	1500*780*1990
Net weight, kg	75







* Special order KN-22S clipper may be manufactured for any type of clips.

ADVANTAGES:

- dosing of the weight of the sausage being filled using a "timer" and a flag" for controlling the filler;
- compatibility with a filler of any manufacturer;
- regulation of stick filling density and overfilling;
- pushers speed adjustment forming the clips on the die;
- clamping drive - manual, clipping drive - pneumatic;
- automatic or manual activation of the cut-off knife;
- fast and easy to readjust for various size of casings;
- by order KN-22S and KN-23S is manufactured to use A type clips;
- versatility, simple maintenance, reliability and low operating costs.

LLC "Machine-building enterprise "KOMPO"

Republic of Belarus
224032 Brest, st. Y. Kupaly, 106 A
www.kompo.com
e-mail: trade@kompo.by



 +375-29-722-09-10
 KOMPO_COM
 kompo_by
 kompoequipment